

A-System 50 Industrial, Kit

Cartridge Assembly 50ml / 1:1

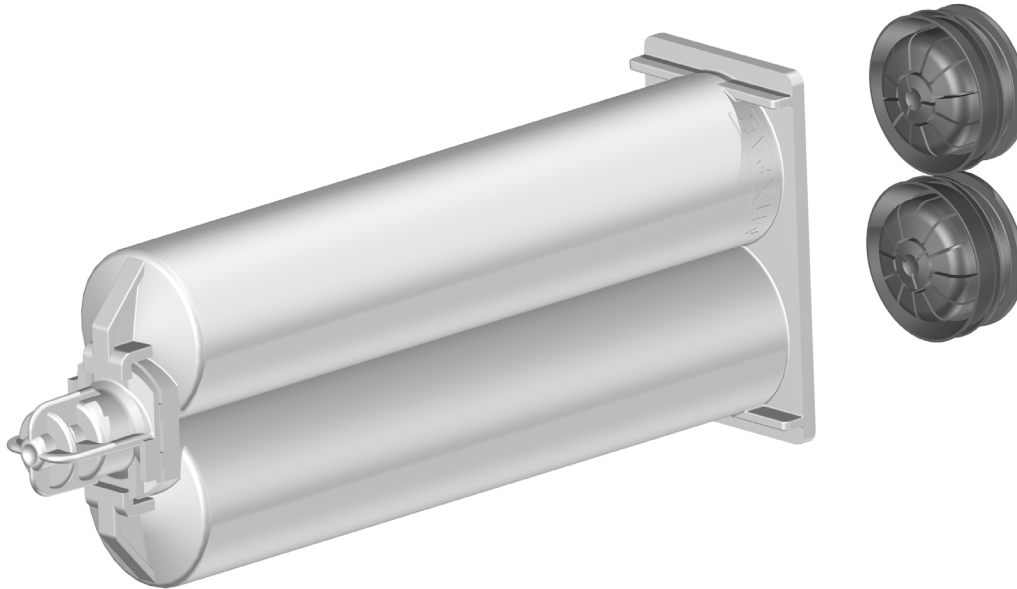

Part number	Article	Description	Units / box
110353	AA 050-01-10-01	Set 50, 1:1, PP white, self-venting lip seal pistons, preassembled cap	1'250
112781	AA 050-01-10-02	Set 50, 1:1, PP white, self-venting lip seal pistons with EPDM O-ring, preassembled cap	1'250
110507	AA 050-01-10-03	Set 50, 1:1, PP white, lip seal pistons with EPDM O-ring, preassembled cap	1'250
116221	AA 050-01-30-01	Set 50, 1:1, PA white, self-venting lip seal pistons, preassembled cap	1'250
116415	AA 050-01-30-02	Set 50, 1:1, PA white, self-venting lip seal pistons with EPDM O-ring, preassembled cap	1'250

Headquarters

Sulzer Mixpac Ltd
phone +41 81 772 20 00
fax +41 81 772 20 01
mixpac@sulzer.com
www.sulzerchemtech.com

USA, South America, Canada and Mexico

Sulzer Mixpac USA Inc.
phone +1 603 893 27 27
fax +1 603 893 37 37
info@SulzerMixpacUSA.com
www.sulzerchemtech.com

UK and Ireland

Sulzer Mixpac UK
phone +44 1536 31 29 90
fax +44 1536 31 29 85
mixpac@sulzer.com
www.sulzerchemtech.com

Asia Pacific

Sulzer Mixpac China
phone +86 21 6430 68 68
fax +86 21 6430 66 88
mixpac@sulzer.com
www.sulzerchemtech.com

A-System 50 Industrial, Kit

Cartridge Assembly 50ml / 2:1

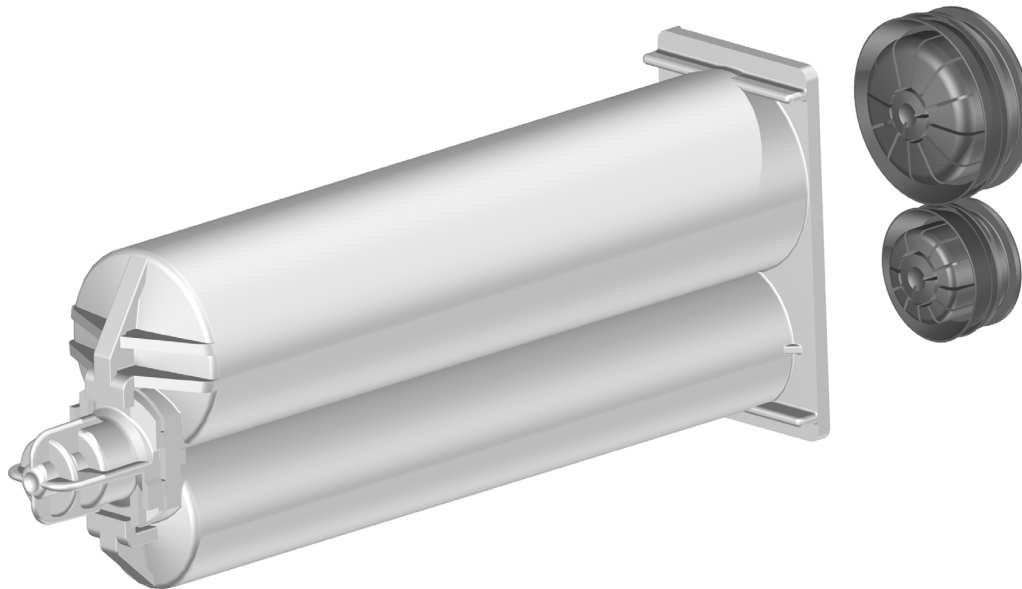

Part number	Article	Description	Units / box
111201	AA 050-02-10-01	Set 50, 2:1, PP white, self-venting lip seal pistons, preassembled cap	1'250
111374	AA 050-02-10-03	Set 50, 2:1, PP white, lip seal pistons with EPDM O-ring, preassembled cap	1'250
116416	AA 050-02-30-01	Set 50, 2:1, PA natural, self-venting lip seal pistons, preassembled cap	1'250

Headquarters

Sulzer Mixpac Ltd
 phone +41 81 772 20 00
 fax +41 81 772 20 01
 mixpac@sulzer.com
 www.sulzerchemtech.com

USA, South America, Canada and Mexico

Sulzer Mixpac USA Inc.
 phone +1 603 893 27 27
 fax +1 603 893 37 37
 info@SulzerMixpacUSA.com
 www.sulzerchemtech.com

UK and Ireland

Sulzer Mixpac UK
 phone +44 1536 31 29 90
 fax +44 1536 31 29 85
 mixpac@sulzer.com
 www.sulzerchemtech.com

Asia Pacific

Sulzer Mixpac China
 phone +86 21 6430 68 68
 fax +86 21 6430 66 88
 mixpac@sulzer.com
 www.sulzerchemtech.com

A-System 50 Industrial, Kit

Cartridge Assembly 42ml / 4:1

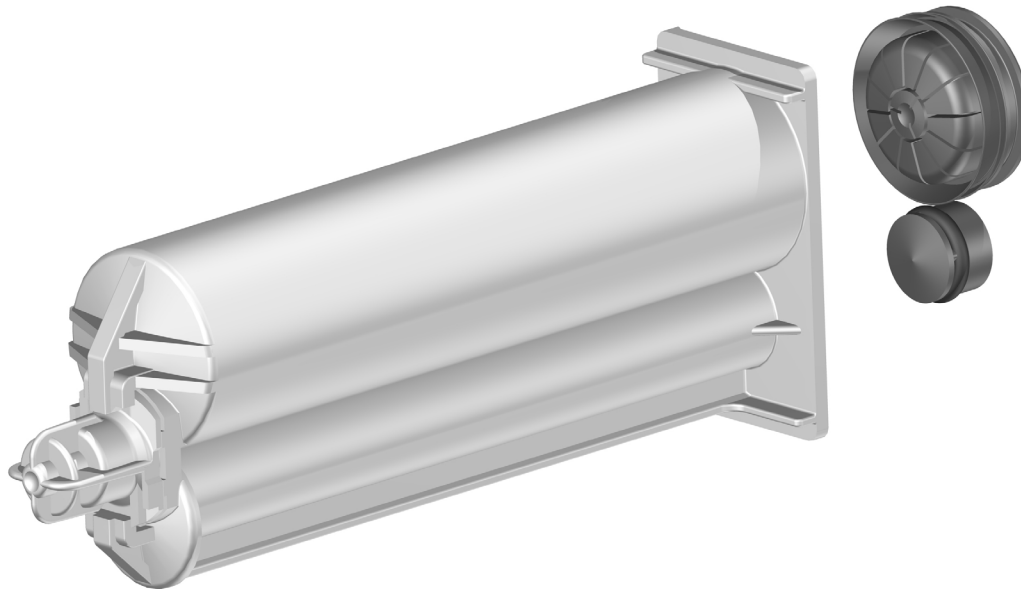

Part number	Article	Description	Units / box
116417	AA 050-04-10-01	Set 50, 4:1, PP white, A-piston airventing lip seal piston, B-piston with EPDM O-ring, preassembled cap	1'250

Headquarters

Sulzer Mixpac Ltd
 phone +41 81 772 20 00
 fax +41 81 772 20 01
 mixpac@sulzer.com
 www.sulzerchemtech.com

USA, South America, Canada and Mexico

Sulzer Mixpac USA Inc.
 phone +1 603 893 27 27
 fax +1 603 893 37 37
 info@SulzerMixpacUSA.com
 www.sulzerchemtech.com

UK and Ireland

Sulzer Mixpac UK
 phone +44 1536 31 29 90
 fax +44 1536 31 29 85
 mixpac@sulzer.com
 www.sulzerchemtech.com

Asia Pacific

Sulzer Mixpac China
 phone +86 21 6430 68 68
 fax +86 21 6430 66 88
 mixpac@sulzer.com
 www.sulzerchemtech.com

A-System 50 Industrial, Kit

Cartridge Assembly 37ml / 10:1

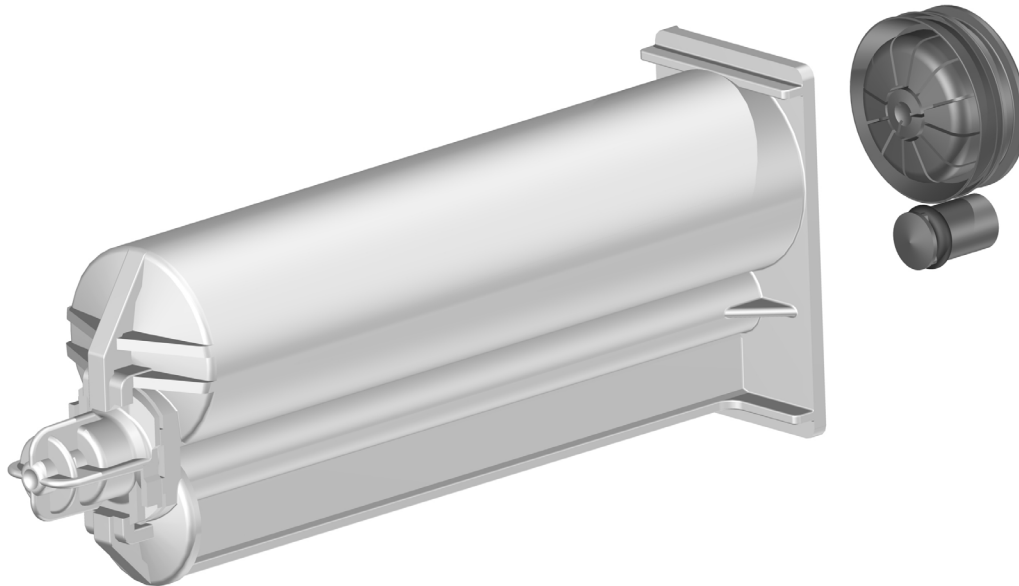

Part number	Article	Description	Units / box
116418	AA 050-10-10-01	Set 50, 10:1, PP white, A-piston airventing lip seal piston, B-piston with EPDM O-ring, preassembled cap	1'250
116419	AA 050-10-30-01	Set 50, 10:1, PA natural, A-piston airventing lip seal piston, B-piston lip seal piston, preassembled cap	1'250

Headquarters

Sulzer Mixpac Ltd
 phone +41 81 772 20 00
 fax +41 81 772 20 01
 mixpac@sulzer.com
 www.sulzerchemtech.com

USA, South America, Canada and Mexico

Sulzer Mixpac USA Inc.
 phone +1 603 893 27 27
 fax +1 603 893 37 37
 info@SulzerMixpacUSA.com
 www.sulzerchemtech.com

UK and Ireland

Sulzer Mixpac UK
 phone +44 1536 31 29 90
 fax +44 1536 31 29 85
 mixpac@sulzer.com
 www.sulzerchemtech.com

Asia Pacific

Sulzer Mixpac China
 phone +86 21 6430 68 68
 fax +86 21 6430 66 88
 mixpac@sulzer.com
 www.sulzerchemtech.com

A-System 75 Industrial, Kit

Cartridge Assembly 75ml / 1:1

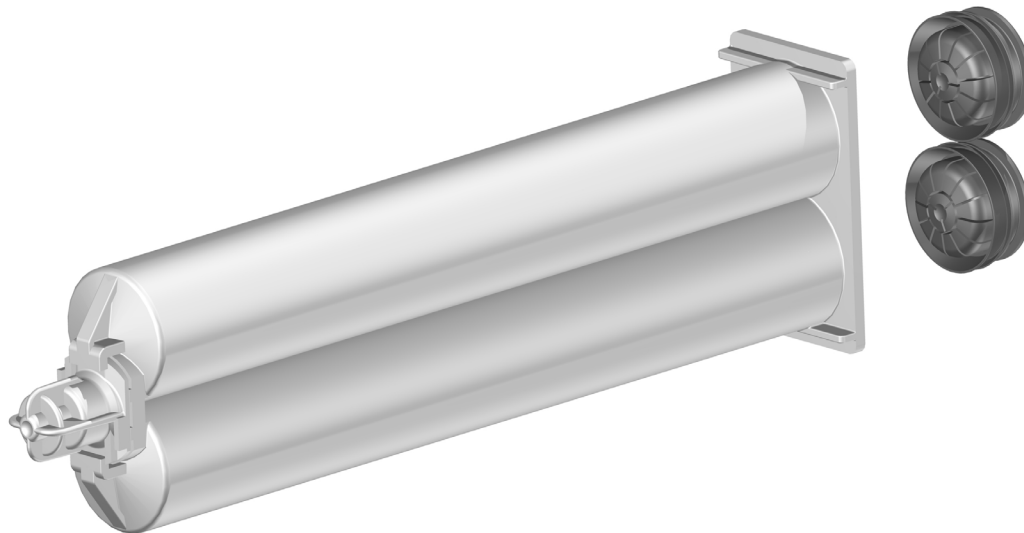

Part number	Article	Description	Units / box
116107	AA 075-01-10-01	Set 75, 1:1, PP white, air venting lip seal pistons, preassembled cap	625

Headquarters

Sulzer Mixpac Ltd
phone +41 81 772 20 00
fax +41 81 772 20 01
mixpac@sulzer.com
www.sulzerchemtech.com

**USA, South America,
Canada and Mexico**

Sulzer Mixpac USA Inc.
phone +1 603 893 27 27
fax +1 603 893 37 37
info@SulzerMixpacUSA.com
www.sulzerchemtech.com

UK and Ireland

Sulzer Mixpac UK
phone +44 1536 31 29 90
fax +44 1536 31 29 85
mixpac@sulzer.com
www.sulzerchemtech.com

Asia Pacific

Sulzer Mixpac China
phone +86 21 6430 68 68
fax +86 21 6430 66 88
mixpac@sulzer.com
www.sulzerchemtech.com

A-System Industrial / Q-System Construction

Mixer Helix for System A/Q, 1:1/2:1

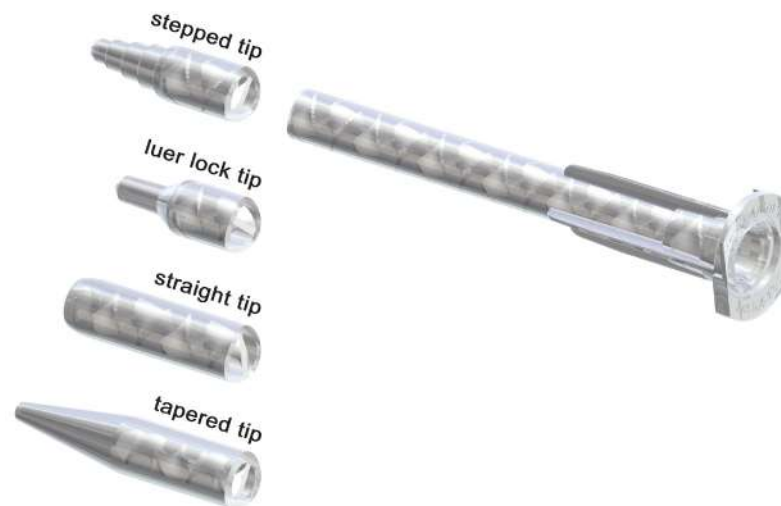

Part number	Article	Description	Elements	Ø (mm)	L (mm)	Vol. (ml)	Units / box
102361	MAH 03-07S	Mixer helix, 1:1/2:1 white elements, tapered tip	7	3.0	34	0.24	15'000
102362	MAH 03-13S	Mixer helix, 1:1/2:1 white elements, tapered tip	13	3.0	57	0.36	12'000
102364	MAH 03-17S	Mixer helix, 1:1/2:1 white elements, tapered tip	17	3.0	63	0.34	10'000
102365	MAH 04-13D	Mixer helix, 1:1/2:1 white elements, straight tip	13	4.0	62	0.60	10'000
102366	MAH 04-13S	Mixer helix, 1:1/2:1 white elements, tapered tip	13	4.0	66	0.60	10'000
102367	MAH 04-17D	Mixer helix, 1:1/2:1 white elements, straight tip	17	4.0	78	0.75	7'000
102368	MAH 04-17S	Mixer helix, 1:1/2:1 white elements, tapered tip	17	4.0	82	0.75	7'500
102369	MAH 05-07T	Mixer helix, 1:1/2:1 white elements, stepped tip	7	5.4	56	0.80	10'000
102370	MAH 05-13D	Mixer helix, 1:1/2:1 white elements, straight tip	13	5.4	79	1.36	7'000

Headquarters

Sulzer Mixpac Ltd
 phone +41 81 772 20 00
 fax +41 81 772 20 01
 mixpac@sulzer.com
 www.sulzerchemtech.com

USA, South America, Canada and Mexico

Sulzer Mixpac USA Inc.
 phone +1 603 893 27 27
 fax +1 603 893 37 37
 info@SulzerMixpacUSA.com
 www.sulzerchemtech.com

UK and Ireland

Sulzer Mixpac UK
 phone +44 1536 31 29 90
 fax +44 1536 31 29 85
 mixpac@sulzer.com
 www.sulzerchemtech.com

Asia Pacific

Sulzer Mixpac China
 phone +86 21 6430 68 68
 fax +86 21 6430 66 88
 mixpac@sulzer.com
 www.sulzerchemtech.com

A-System Industrial / Q-System Construction

Mixer Helix for System A/Q, 1:1/2:1

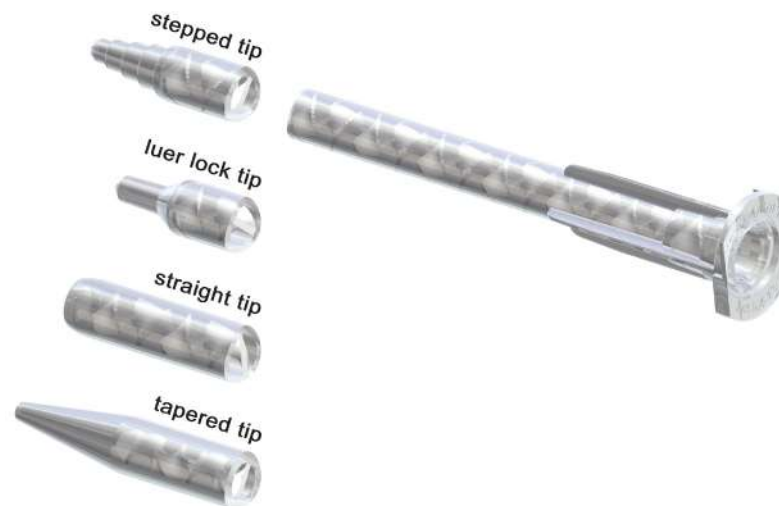

Part number	Article	Description	Elements	Ø (mm)	L (mm)	Vol. (ml)	Units / box
102371	MAH 05-13T	Mixer helix, 1:1/2:1 white elements, stepped tip	13	5.4	85	1.36	6'500
102360	MAH 0517-0413T	Mixer helix, 1:1/2:1 white elements, 17 elements 5.3, 13 elements 4.0, stepped tip	17+13	5.4/4.0	150	2.07	4'000
102372	MAH 05-17T	Mixer helix, 1:1/2:1 white elements, stepped tip	17	5.4	104	1.68	4'000
102373	MAH 05-21T	Mixer helix, 1:1/2:1 white elements, stepped tip	21	5.4	124	2.01	3'000
102375	MAH 06-12D	Mixer helix, 1:1/2:1 white elements, straight tip	12	6.3	85.8	2.08	5'000
102377	MAH 06-12T	Mixer helix, 1:1/2:1 white elements, stepped tip	12	6.3	97	2.08	4'500
102378	MAH 06-17T	Mixer helix, 1:1/2:1 white elements, stepped tip	17	6.3	128.5	2.94	3'000
102379	MAH 06-21L	Mixer helix, 1:1/2:1 white elements, luer lock tip	21	6.3	151	3.33	4'000
102380	MAH 06-21T	Mixer helix, 1:1/2:1 white elements, stepped tip	21	6.3	153	3.57	2'500

Headquarters

Sulzer Mixpac Ltd
phone +41 81 772 20 00
fax +41 81 772 20 01
mixpac@sulzer.com
www.sulzerchemtech.com

USA, South America, Canada and Mexico

Sulzer Mixpac USA Inc.
phone +1 603 893 27 27
fax +1 603 893 37 37
info@SulzerMixpacUSA.com
www.sulzerchemtech.com

UK and Ireland

Sulzer Mixpac UK
phone +44 1536 31 29 90
fax +44 1536 31 29 85
mixpac@sulzer.com
www.sulzerchemtech.com

Asia Pacific

Sulzer Mixpac China
phone +86 21 6430 68 68
fax +86 21 6430 66 88
mixpac@sulzer.com
www.sulzerchemtech.com

A-System Industrial / Q-System Construction

Mixer Helix for System A/Q, 4:1/10:1



Part number	Article	Description	Elements	Ø (mm)	L (mm)	Vol. (ml)	Units / box
102535	MAHX 04-17S	Mixer helix, 4:1/10:1 orange elements, tapered tip	17	4.0	81.6	0.75	7'500
102536	MAHX 05-17T	Mixer helix, 4:1/10:1 orange elements, stepped tip	17	5.4	103.4	1.68	4'000

Headquarters

Sulzer Mixpac Ltd
phone +41 81 772 20 00
fax +41 81 772 20 01
mixpac@sulzer.com
www.sulzerchemtech.com

USA, South America, Canada and Mexico

Sulzer Mixpac USA Inc.
phone +1 603 893 27 27
fax +1 603 893 37 37
info@SulzerMixpacUSA.com
www.sulzerchemtech.com

UK and Ireland

Sulzer Mixpac UK
phone +44 1536 31 29 90
fax +44 1536 31 29 85
mixpac@sulzer.com
www.sulzerchemtech.com

Asia Pacific

Sulzer Mixpac China
phone +86 21 6430 68 68
fax +86 21 6430 66 88
mixpac@sulzer.com
www.sulzerchemtech.com

A-System Industrial / Q-System Construction

Mixer Quadro for System A/Q



Part number	Article	Description	Elements	∅ (mm)	L (mm)	Vol. (ml)	Units / box
300028	MAQ 05-16L	Mixer quadro green elements, luer lock tip	16	5.3	83	1.30	5'000
300026	MAQ 05-24L	Mixer quadro green elements, luer lock tip	24	5.3	115	1.90	3'000

Headquarters

Sulzer Mixpac Ltd
phone +41 81 772 20 00
fax +41 81 772 20 01
mixpac@sulzer.com
www.sulzerchemtech.com

USA, South America, Canada and Mexico

Sulzer Mixpac USA Inc.
phone +1 603 893 27 27
fax +1 603 893 37 37
info@SulzerMixpacUSA.com
www.sulzerchemtech.com

UK and Ireland

Sulzer Mixpac UK
phone +44 1536 31 29 90
fax +44 1536 31 29 85
mixpac@sulzer.com
www.sulzerchemtech.com

Asia Pacific

Sulzer Mixpac China
phone +86 21 6430 68 68
fax +86 21 6430 66 88
mixpac@sulzer.com
www.sulzerchemtech.com